

Precision Dual/Quad CMOS Rail-to-Rail Input/Output Amplifiers

FEATURES

- **Maximum Offset Voltage: 70 μ V (25 $^{\circ}$ C)**
- **Maximum Offset Drift: 0.8 μ V/ $^{\circ}$ C**
- **Maximum Input Bias: 1pA (25 $^{\circ}$ C) 40pA ($T_A \leq 85^{\circ}$ C)**
- Open Loop Voltage Gain: 120dB Typ
- Gain Bandwidth Product: 3.6MHz
- CMRR: 100dB Min
- PSRR: 98dB Min
- 0.1Hz to 10Hz Noise: 1.3 μ V_{P-P}
- Supply Current: 330 μ A
- Rail-to-Rail Inputs and Outputs
- Unity Gain Stable
- 2.7V to 5.5V Operation Voltage
- Dual LTC6081 in 8-Lead MSOP and 10-Lead DFN10 Packages; Quad LTC6082 in 16-Lead SSOP and DFN Packages

APPLICATIONS

- Photodiode Amplifier
- Strain Gauge
- High Impedance Sensor Amplifier
- Microvolt Accuracy Threshold Detection
- Instrumentation Amplifiers
- Thermocouple Amplifiers

DESCRIPTION

The **LTC[®]6081/LTC6082** are dual/quad low offset, low drift, low noise CMOS operational amplifiers with rail-to-rail input/output swing.

The 70 μ V maximum offset, 1pA input bias current, 120dB open loop gain and 1.3 μ V_{P-P} 0.1Hz to 10Hz noise make it perfect for precision signal conditioning. The LTC6081/LTC6082 features 100dB CMRR and 98dB PSRR.

Each amplifier consumes only 330 μ A of current on a 3V supply. The 10-lead DFN has an independent shutdown function that reduces each amplifier's supply current to 1 μ A.

LTC6081/LTC6082 is specified for power supply voltages of 3V and 5V from -40 $^{\circ}$ C to 125 $^{\circ}$ C. The dual LTC6081 is available in 8-lead MSOP and 10-lead DFN10 packages. The quad LTC6082 is available in 16-lead SSOP and DFN packages.

LT, LTC, LTM, Linear Technology and the Linear logo are registered trademarks of Linear Technology Corporation. All other trademarks are the property of their respective owners.

TYPICAL APPLICATION

Shock Sensor Amplifier (Accelerometer)

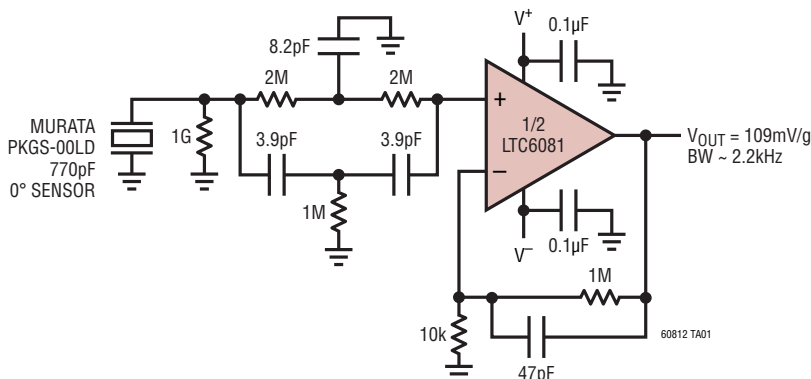

V_{OS} Drift Histogram

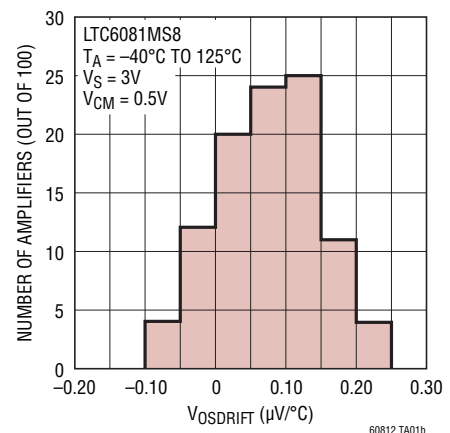

ABSOLUTE MAXIMUM RATINGS

(Note 1)

Total Supply Voltage (V^+ to V^-).....	6V
Input Voltage.....	V^- to V^+
Output Short Circuit Duration (Note 2).....	Indefinite
Operating Temperature Range (Note 3)	
LTC6081C, LTC6082C	-40°C to 85°C
LTC6081I, LTC6082I	-40°C to 85°C
LTC6081H, LTC6082H	-40°C to 125°C
(H Temperature Range Not Available in DFN Package)	

Specified Temperature Range (Note 4)	
LTC6081C, LTC6082C	0°C to 70°C
LTC6081I, LTC6082I	-40°C to 85°C
LTC6081H, LTC6082H	-40°C to 125°C
Junction Temperature	
DFN Packages	125°C
All Other Packages	150°C
Storage Temperature Range	
DFN Packages	-65°C to 125°C
All Other Packages	-65°C to 150°C
Lead Temperature (Soldering, 10 Sec).....	300°C

PIN CONFIGURATION

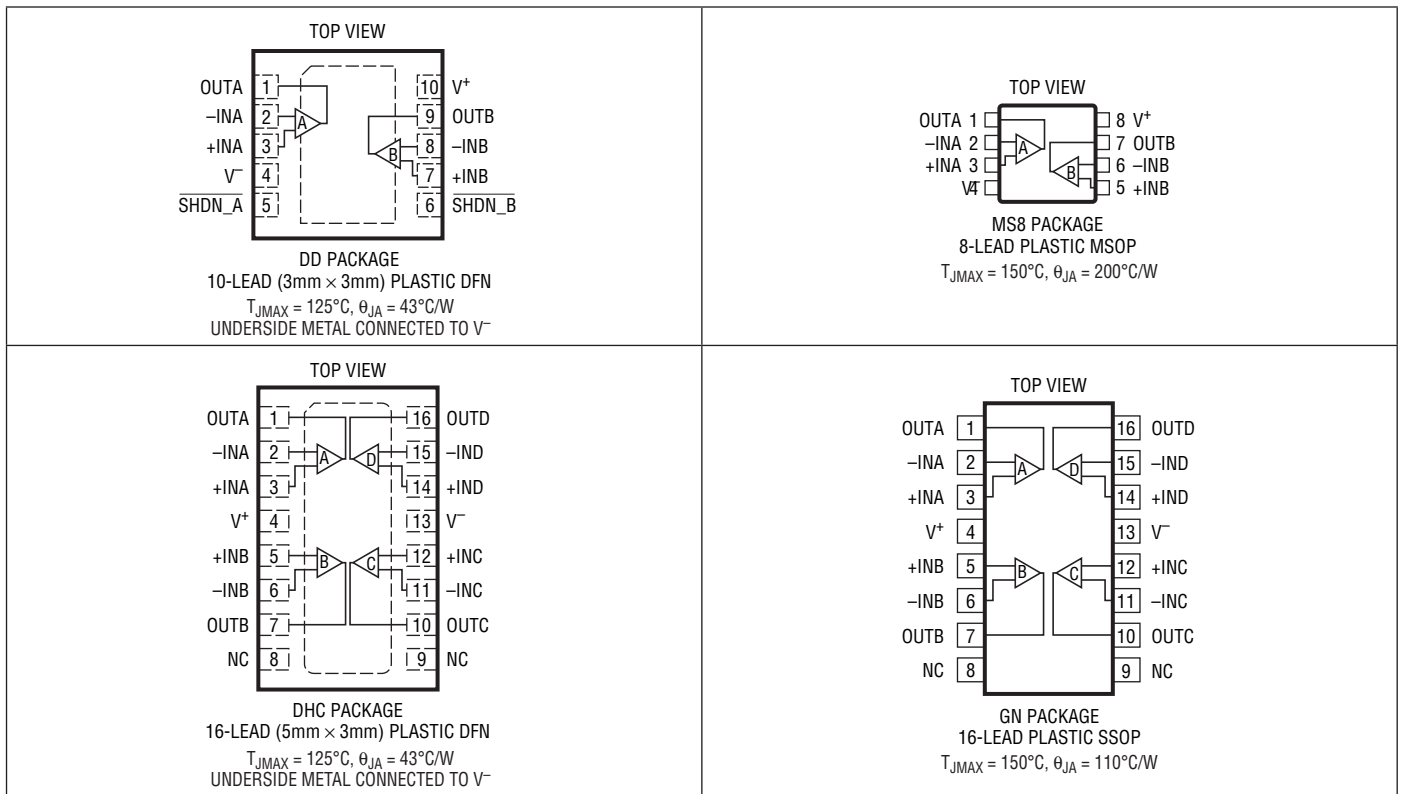

ORDER INFORMATION

LEAD FREE FINISH	TAPE AND REEL	PART MARKING*	PACKAGE DESCRIPTION	SPECIFIED TEMPERATURE RANGE
LTC6081CDD#PBF	LTC6081CDD#TRPBF	LCJP	10-Lead (3mm × 3mm) Plastic DFN	0°C to 70°C
LTC6081IDD#PBF	LTC6081IDD#TRPBF	LCJP	10-Lead (3mm × 3mm) Plastic DFN	-40°C to 85°C
LTC6081CMS8#PBF	LTC6081CMS8#TRPBF	LTCJN	8-Lead Plastic MSOP	0°C to 70°C
LTC6081IMS8#PBF	LTC6081IMS8#TRPBF	LTCJN	8-Lead Plastic MSOP	-40°C to 85°C
LTC6081HMS8#PBF	LTC6081HMS8#TRPBF	LTCJN	8-Lead Plastic MSOP	-40°C to 125°C
LTC6082CDHC#PBF	LTC6082CDHC#TRPBF	6082	16-Lead (5mm × 3mm) Plastic DFN	0°C to 70°C
LTC6082IDHC#PBF	LTC6082IDHC#TRPBF	6082	16-Lead (5mm × 3mm) Plastic DFN	-40°C to 85°C
LTC6082CGN#PBF	LTC6082CGN#TRPBF	6082	16-Lead Plastic SSOP	0°C to 70°C
LTC6082IGN#PBF	LTC6082IGN#TRPBF	6082I	16-Lead Plastic SSOP	-40°C to 85°C
LTC6082HGN#PBF	LTC6082HGN#TRPBF	6082H	16-Lead Plastic SSOP	-40°C to 125°C

Consult LTC Marketing for parts specified with wider operating temperature ranges. *The temperature grade is identified by a label on the shipping container. Consult LTC Marketing for information on non-standard lead based finish parts.

For more information on lead free part marking, go to: <http://www.linear.com/leadfree/>

For more information on tape and reel specifications, go to: <http://www.linear.com/tapeandree/>

LTC6081IDD

ELECTRICAL CHARACTERISTICS

The ● denotes the specifications which apply over the full operating temperature range, otherwise specifications are at $T_A = 25^\circ\text{C}$. Test conditions are $V^+ = 3\text{V}$, $V^- = 0\text{V}$, $V_{\text{CM}} = 0.5\text{V}$ unless otherwise noted.

SYMBOL	PARAMETER	CONDITIONS	C, I SUFFIXES			H SUFFIX			UNITS
			MIN	TYP	MAX	MIN	TYP	MAX	
V_{OS}	Offset Voltage	LTC6081MS8, LTC6082GN	$V_{\text{CM}} = 0.5\text{V}, 2.5\text{V}$	●	-70	70	-70	70	μV
		LTC6081MS8, LTC6082GN	$V_{\text{CM}} = 0.5\text{V}, 2.5\text{V}$	●	-90	90	-90	90	μV
		LTC6081DD, LTC6082DHC	$V_{\text{CM}} = 0.5\text{V}, 2.5\text{V}$	●	-70	70			μV
		LTC6081DD, LTC6082DHC	$V_{\text{CM}} = 0.5\text{V}, 2.5\text{V}$	●	-90	90			μV
$\Delta V_{\text{OS}}/\Delta T$	Input Offset Voltage Drift (Note 5)		●	± 0.2	± 0.8	± 0.2	± 0.8	$\mu\text{V}/^\circ\text{C}$	
I_{B}	Input Bias Current (Note 6)		●	0.2	1 40	0.2	1 500	pA pA	
I_{OS}	Input Offset Current		●	0.1	15	0.1	100	pA pA	
e_{n}	Input Referred Noise	Noise Density at $f = 1\text{kHz}$ Integrated Noise From 0.1Hz to 10Hz		13 1.3		13 1.3		$\text{nV}/\sqrt{\text{Hz}}$ $\mu\text{V}_{\text{P-P}}$	
I_{n}	Input Noise Current Density (Note 7)			0.5		0.5		$\text{fA}/\sqrt{\text{Hz}}$	
	Input Common Mode Range		●	V^-	V^+	V^-	V^+	V	
C_{DIFF}	Differential Input Capacitance			3		3		pF	
C_{CM}	Common Mode Input Capacitance			7		7		pF	
CMRR	Common Mode Rejection Ratio	$V_{\text{CM}} = 0\text{V}$ to 1.5V	●	95	105	95	105	dB	
		$V_{\text{CM}} = 0\text{V}$ to 1.5V	●	88	100	86	100	dB	
		$V_{\text{CM}} = 0\text{V}$ to 3V	●	93	105	93	105	dB	
		$V_{\text{CM}} = 0\text{V}$ to 3V	●	88	100	86	100	dB	
PSRR	Power Supply Rejection Ratio	$V_{\text{S}} = 2.7\text{V}$ to 5.5V	●	98 96	110	98 96	110	dB dB	
V_{OUT}	Output Voltage, High, Either Output Pin	No Load	●		1		1	mV	
		$I_{\text{SOURCE}} = 0.5\text{mA}$	●	-32		-35		mV	
	$I_{\text{SOURCE}} = 5\text{mA}$	●	-320		-350		mV		
	Output Voltage, Low, Either Output Pin (Referred to V^-)	No Load	●		1		1	mV	
		$I_{\text{SINK}} = 0.5\text{mA}$	●		33		40	mV	
		$I_{\text{SINK}} = 5\text{mA}$	●		300		360	mV	
A_{VOL}	Large-Signal Voltage Gain	$R_{\text{LOAD}} = 10\text{k}$, $0.5\text{V} < V_{\text{OUT}} < 2.5\text{V}$	●	110	120	110	120	dB	
I_{SC}	Output Short-Circuit Current	Source	●	17		15		mA	
		Sink	●	17		15		mA	
SR	Slew Rate	$A_{\text{V}} = 1$		1		1		V/ μs	
GBW	Gain-Bandwidth Product ($f_{\text{TEST}} = 50\text{kHz}$)		●	2.5	3.6	2.5	3.6	MHz	
				1.8		1.5		MHz	
Φ_0	Phase Margin	$R_{\text{L}} = 10\text{k}$		70		70		Deg	
t_{S}	Settling Time 0.1%	$A_{\text{V}} = 1$, 1V Step		6		6		μs	
I_{S}	Supply Current (Per Amplifier)	No Load	●	330	400 435	330	400 460	μA μA	
	Shutdown Current (Per Amplifier)	Shutdown, $V_{\text{SHDN}} \leq 0.8\text{V}$	●	0.5	2			μA μA	
V_{S}	Supply Voltage Range	Guaranteed by the PSRR Test	●	2.7	5.5	2.7	5.5	V	
	Channel Separation	$f_{\text{S}} = 10\text{kHz}$, $R_{\text{L}} = 10\text{k}$		-120		-120		dB	

ELECTRICAL CHARACTERISTICS

The ● denotes the specifications which apply over the full operating temperature range, otherwise specifications are at $T_A = 25^\circ\text{C}$. Test conditions are $V^+ = 3\text{V}$, $V^- = 0\text{V}$, $V_{\text{CM}} = 0.5\text{V}$ unless otherwise noted.

SYMBOL	PARAMETER	CONDITIONS	C, I SUFFIXES			H SUFFIX			UNITS	
			MIN	TYP	MAX	MIN	TYP	MAX		
	Shutdown Logic	$\overline{\text{SHDN}}$ High $\overline{\text{SHDN}}$ Low	● ●	2		0.8	2		0.8	V V
THD	Total Harmonic Distortion	$f = 10\text{kHz}$, $V^+ = 3\text{V}$, $V_{\text{OUT}} = 1\text{V}_{\text{P-P}}$, $R_L = 10\text{k}$			-90			-90		dB
t_{ON}	Turn-On Time	$V_{\overline{\text{SHDN}}} = 0.8\text{V}$ to 2V			10			10		μs
t_{OFF}	Turn-Off Time	$V_{\overline{\text{SHDN}}} = 2\text{V}$ to 0.8V			2			2		μs
	$\overline{\text{SHDN}}$ Pin Current	$V_{\overline{\text{SHDN}}} = 0\text{V}$	●			2				μA

The ● denotes the specifications which apply over the full operating temperature range, otherwise specifications are at $T_A = 25^\circ\text{C}$. Test conditions are $V^+ = 5\text{V}$, $V^- = 0\text{V}$, $V_{\text{CM}} = 0.5\text{V}$ unless otherwise noted.

SYMBOL	PARAMETER	CONDITIONS	C, I SUFFIXES			H SUFFIX			UNITS	
			MIN	TYP	MAX	MIN	TYP	MAX		
V_{OS}	Offset Voltage	LTC6081MS8, LTC6082GN $V_{\text{CM}} = 0.5\text{V}$	●	-70		70	-70		70	μV
		LTC6081MS8, LTC6082GN $V_{\text{CM}} = 0.5\text{V}$	●	-90		90	-90		90	μV
		LTC6081DD, LTC6082DHC $V_{\text{CM}} = 0.5\text{V}$	●	-70		70				μV
		LTC6081DD, LTC6082DHC $V_{\text{CM}} = 0.5\text{V}$	●	-90		90				μV
$\Delta V_{\text{OS}}/\Delta T$	Input Offset Voltage Drift (Note 8)		●	± 0.2		± 0.8	± 0.2		± 0.8	$\mu\text{V}/^\circ\text{C}$
I_{B}	Input Bias Current		●		0.2		0.2		500	pA pA
I_{OS}	Input Offset Current		●		0.1		0.1		100	pA pA
e_{n}	Input Referred Noise	$f = 1\text{kHz}$			13		13			$\text{nV}/\sqrt{\text{Hz}}$
		0.1Hz to 10Hz			1.3		1.3			$\mu\text{V}_{\text{P-P}}/\sqrt{\text{Hz}}$
I_{n}	Input Noise Current Density (Note 7)				0.5		0.5			$\text{fA}/\sqrt{\text{Hz}}$
	Input Common Mode Range		●	V^-		V^+	V^-		V^+	V
C_{DIFF}	Differential Input Capacitance				3		3			pF
C_{CM}	Common Mode Input Capacitance				7		7			pF
CMRR	Common Mode Rejection Ratio	$V_{\text{CM}} = 0\text{V}$ to 3.5V	●	100		110	100		110	dB
		$V_{\text{CM}} = 0\text{V}$ to 3.5V	●	95		110	94		110	dB
		$V_{\text{CM}} = 0\text{V}$ to 5V	●	86		95	86		95	dB
PSRR	Power Supply Rejection Ratio	$V_{\text{S}} = 2.7\text{V}$ to 5.5V	●	98		110	98		110	dB
			●	96			96			dB
V_{OUT}	Output Voltage, High, Either Output Pin (Referred to V^+)	No Load	●			1			1	mV
		$I_{\text{SOURCE}} = 0.5\text{mA}$	●	-24			-25			mV
		$I_{\text{SOURCE}} = 5\text{mA}$	●	-200			-220			mV
V_{OUT}	Output Voltage, Low, Either Output Pin (Referred to V^-)	No Load	●			1			1	mV
		$I_{\text{SINK}} = 0.5\text{mA}$	●						32	mV
		$I_{\text{SINK}} = 5\text{mA}$	●			27		210	240	mV
A_{VOL}	Large-Signal Voltage Gain	$R_{\text{LOAD}} = 10\text{k}$, $0.5\text{V} < V_{\text{OUT}} < 4.5\text{V}$	●	110		120	110		120	dB

ELECTRICAL CHARACTERISTICS

The ● denotes the specifications which apply over the full operating temperature range, otherwise specifications are at $T_A = 25^\circ\text{C}$. Test conditions are $V^+ = 5\text{V}$, $V^- = 0\text{V}$, $V_{\text{CM}} = 0.5\text{V}$ unless otherwise noted.

SYMBOL	PARAMETER	CONDITIONS	C, I SUFFIXES			H SUFFIX			UNITS	
			MIN	TYP	MAX	MIN	TYP	MAX		
I_{SC}	Output Short-Circuit Current	Source	●	24			21		mA	
			●	24			21		mA	
SR	Slew Rate	$A_V = 1$		1			1		V/ μs	
GBW	Gain-Bandwidth Product ($f_{\text{TEST}} = 50\text{kHz}$)	$R_L = 100\text{k}$	●	2.5 1.8	3.5		2.5 1.5	3.5	MHz MHz	
Φ_0	Phase Margin	$R_L = 10\text{k}$		70			70		Deg	
t_S	Settling Time 0.1%	$A_V = 1$, 1V Step		6			6		μs	
I_S	Supply Current (Per Amplifier)	No Load	●		340 425 465			340 425 490	μA μA	
	Shutdown Current (Per Amplifier)	Shutdown, $V_{\text{SHDN}} \leq 1.2\text{V}$	●		6				μA	
V_S	Supply Voltage Range	Guaranteed by the PSRR Test	●	2.7		5.5	2.7		5.5	V
	Channel Separation	$f_s = 10\text{kHz}$, $R_L = 10\text{k}$			-120			-120		dB
	Shutdown Logic	$\overline{\text{SHDN}}$ High $\overline{\text{SHDN}}$ Low	● ●	3.5		1.2	3.5		1.2	V V
THD	Total Harmonic Distortion	$f = 10\text{kHz}$, $V^+ = 5\text{V}$, $V_{\text{OUT}} = 2V_{\text{P-P}}$, $R_L = 10\text{k}$			-90			-90		dB
t_{ON}	Turn-On Time	$V_{\text{SHDN}} = 1.2\text{V}$ to 3.5V			10			10		μs
t_{OFF}	Turn-Off Time	$V_{\text{SHDN}} = 3.5\text{V}$ to 1.2V			2			2		μs
	$\overline{\text{SHDN}}$ Pin Current	$V_{\text{SHDN}} = 0\text{V}$	●			2				μA

Note 1: Stresses beyond those listed under Absolute Maximum Ratings may cause permanent damage to the device. Exposure to any Absolute Maximum Rating condition for extended periods may affect device reliability and lifetime.

Note 2: A heat sink may be required to keep the junction temperature below the absolute maximum. This depends on the power supply voltage and how many amplifiers are shorted.

Note 3: The LTC6081C/LTC6082C and LTC6081I/LTC6082I are guaranteed functional over the operating temperature range of -40°C to 85°C . The LTC6081H/LTC6082H are guaranteed functional over the operating temperature range of -40°C to 125°C .

Note 4: The LTC6081C/LTC6082C are guaranteed to meet specified performance from 0°C to 70°C . The LTC6081C/LTC6082C are designed,

characterized and expected to meet specified performance from -40°C to 85°C but are not tested or QA sampled at these temperatures. The LTC6081I/LTC6082I are guaranteed to meet specified performance from -40°C to 85°C . The LTC6081H/LTC6082H are guaranteed to meet specified performance from -40°C to 125°C .

Note 5: Input offset drift is computed from the limits of the V_{OS} test divided by the temperature range. This is a conservative estimate of worst case drift. Consult the Typical Performance Characteristics section for more information on input offset drift.

Note 6: I_B guaranteed by the $V_S = 5\text{V}$ test.

Note 7: Current noise is calculated from $I_n = \sqrt{2qI_B}$, where $q = 1.6 \cdot 10^{-19}$ coulomb.

Note 8: V_{OS} drift is guaranteed by the $V_S = 3\text{V}$ test.

TYPICAL PERFORMANCE CHARACTERISTICS

V_{OS} Drift Histogram

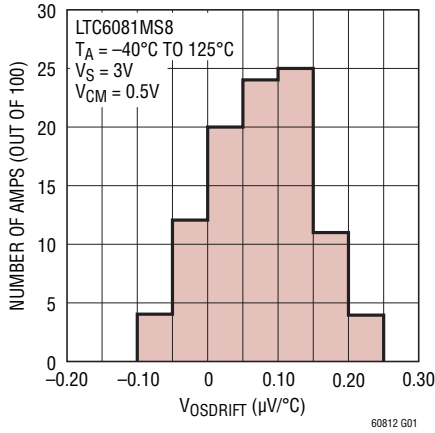

V_{OS} Drift Histogram

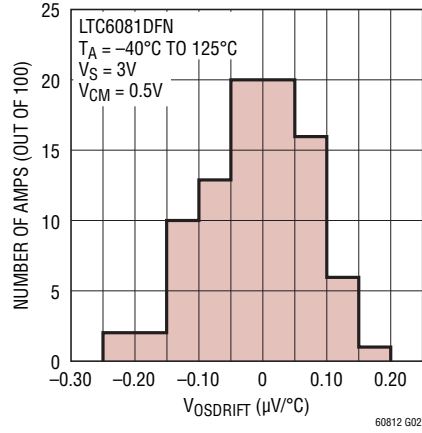

V_{OS} vs Temperature

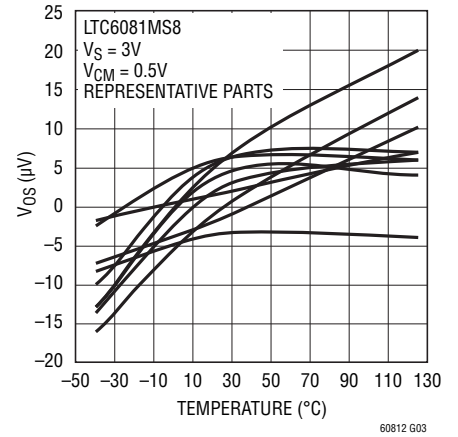

V_{OS} Histogram

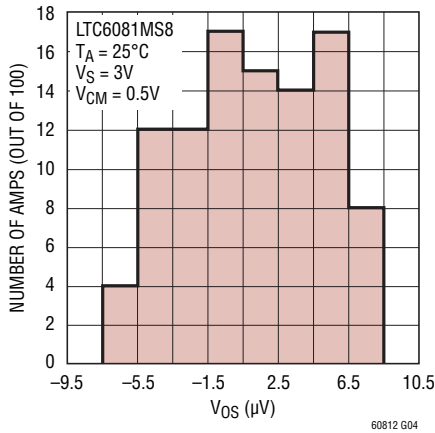

V_{OS} vs V_{CM}

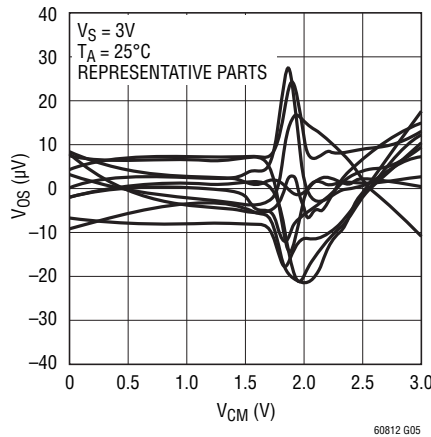

V_{OS} vs V_{CM}

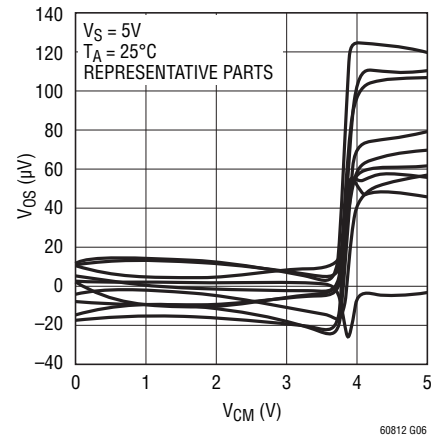

V_{OS} vs Output Current

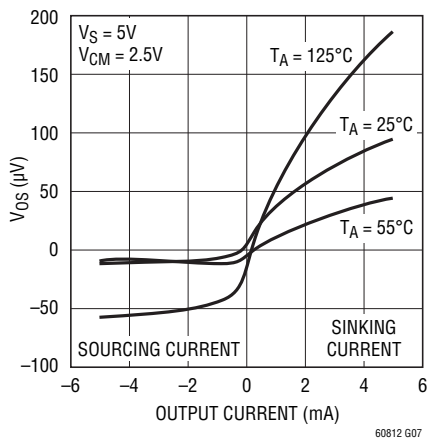

Warm-Up Drift vs Time

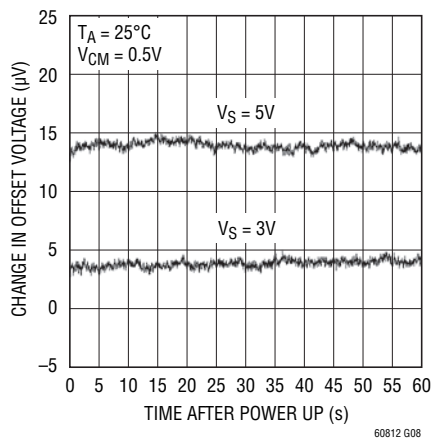

Noise Voltage vs Frequency

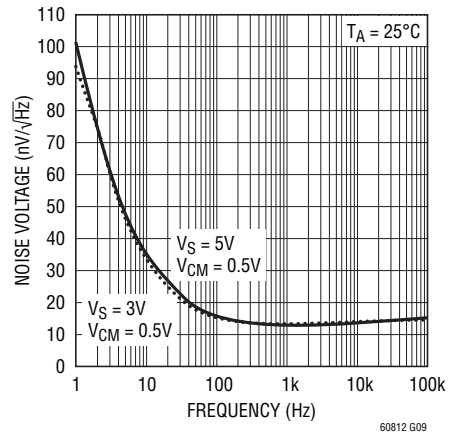

TYPICAL PERFORMANCE CHARACTERISTICS

Noise Voltage vs Frequency

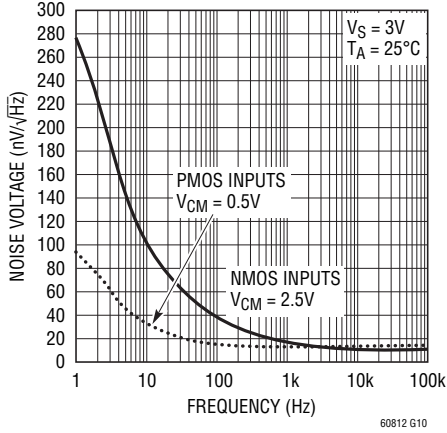

0.1Hz to 10Hz Output Voltage Noise

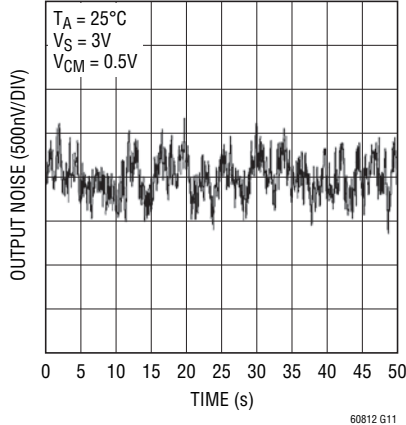

0.1Hz to 10Hz Output Voltage Noise

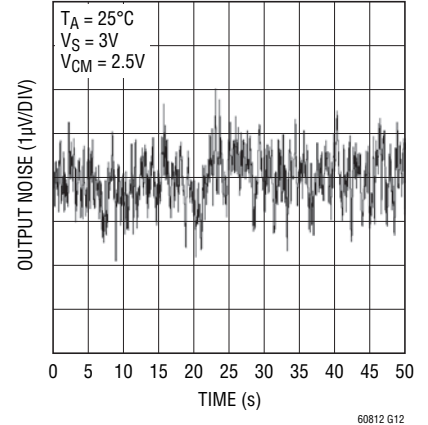

Input Bias Current vs Temperature

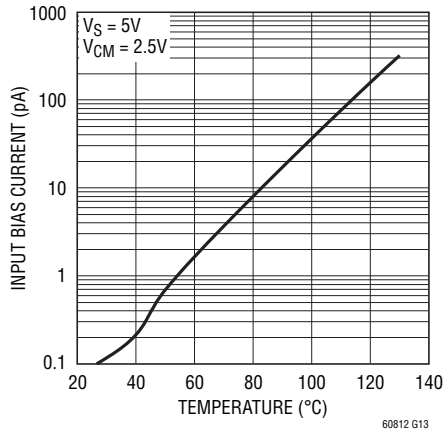

I_{BIAS} vs V_{CM}

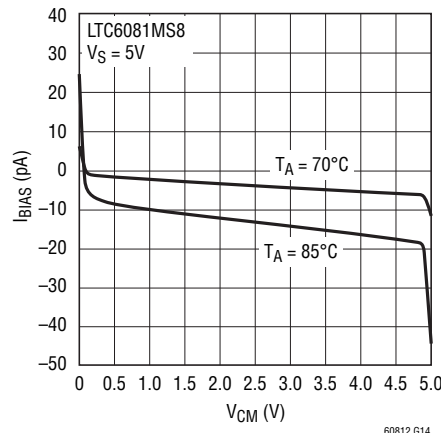

I_{BIAS} vs V_{CM}

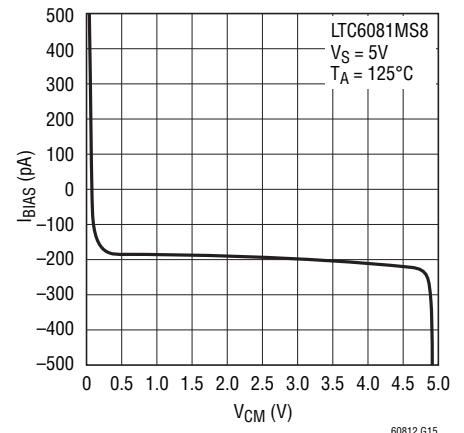

Large Signal Transient

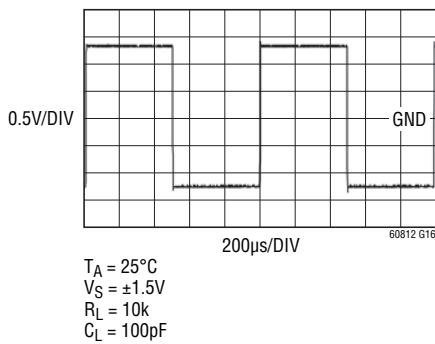

Small Signal Transient

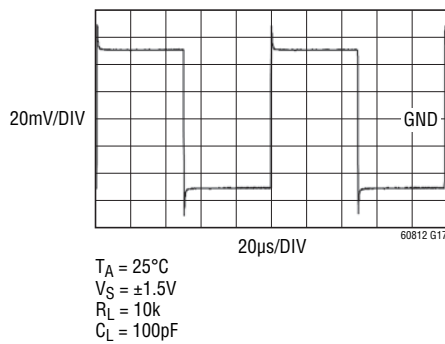

Overshoot vs C_L

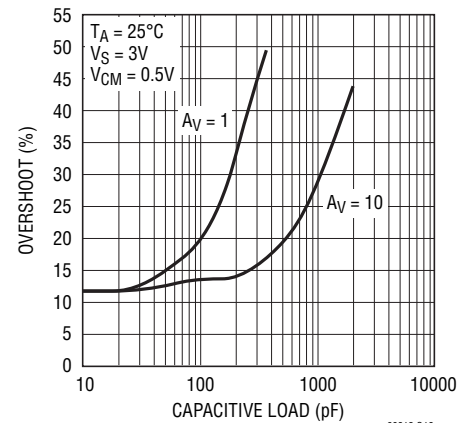

TYPICAL PERFORMANCE CHARACTERISTICS

Supply Current vs Temperature

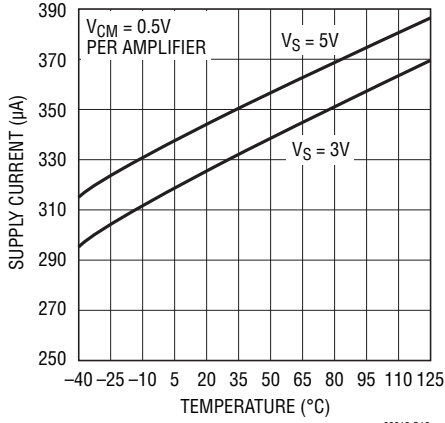

Supply Current vs Time

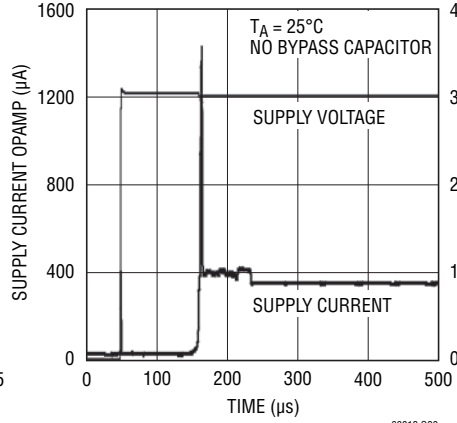

Output Impedance vs Frequency

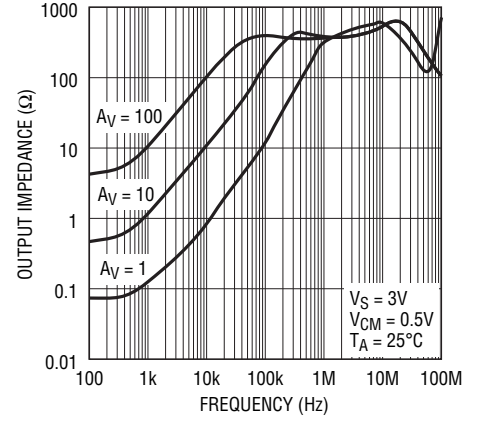

Open Loop Gain

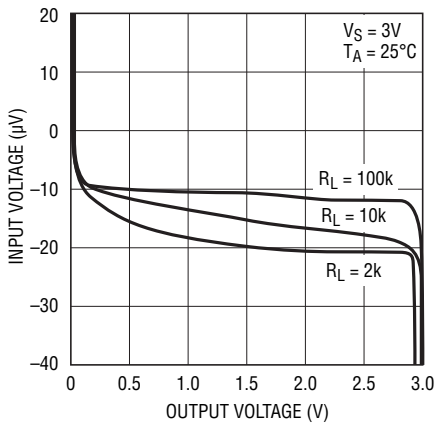

Open Loop Gain

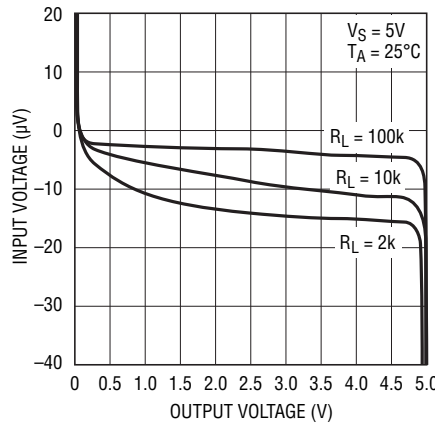

Open Loop Gain vs Frequency

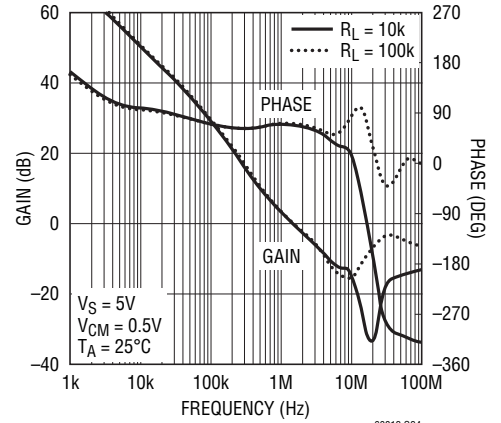

Open Loop Gain vs Frequency

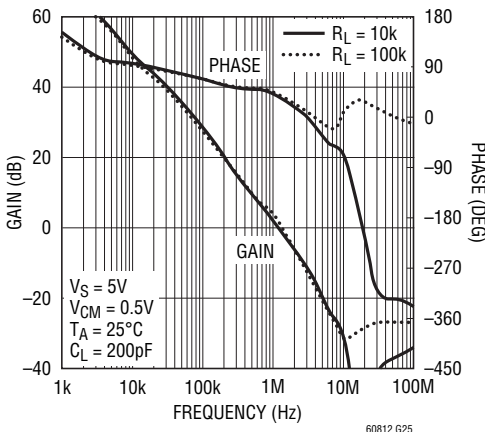

CMRR vs Frequency

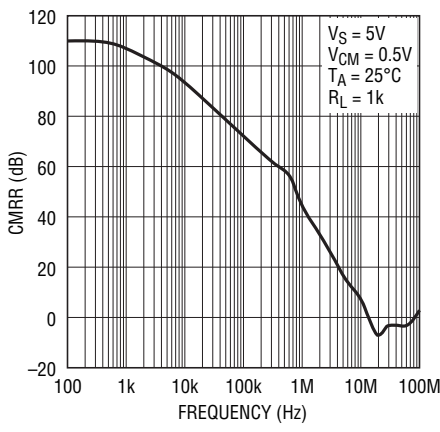

PSRR vs Frequency

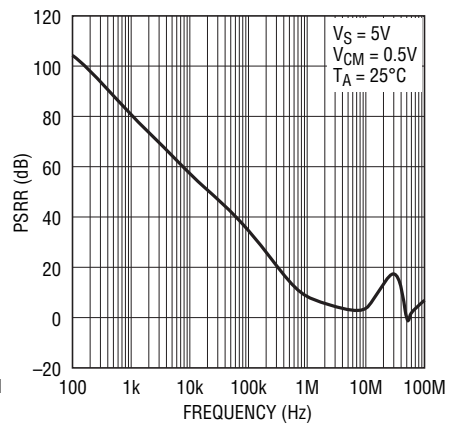

TYPICAL PERFORMANCE CHARACTERISTICS

Channel Separation vs Frequency

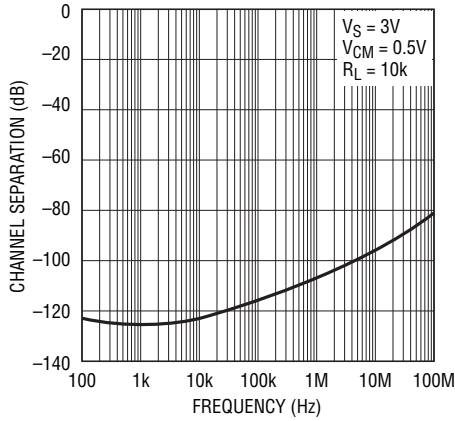

60812 G28

Output Voltage Swing vs Load Current

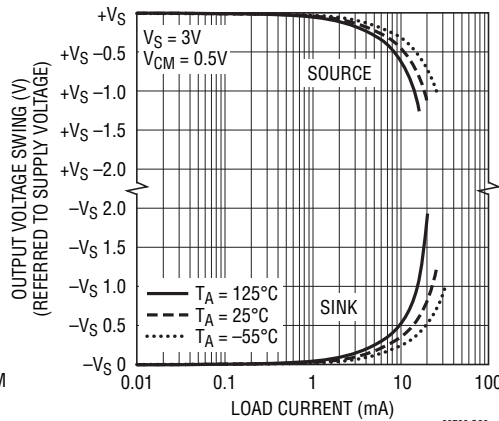

60789 G29

Distortion vs Frequency

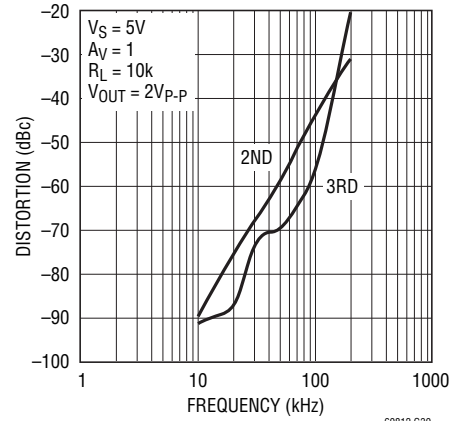

60812 G30

PIN FUNCTIONS

OUT: Amplifier Output

-IN: Inverting Input

+IN: Noninverting Input

V+: Positive Supply

V-: Negative Supply

SHDN_A: Shutdown Pin of Amplifier A, active low and only valid for LTC6081DD. An internal current source pulls the pin to V+ when floating.

SHDN_B: Shutdown Pin of Amplifier B, active low and only valid for LTC6081DD. An internal current source pulls the pin to V+ when floating.

NC: Not internally connected.

Exposed Pad: Connected to V-.

APPLICATIONS INFORMATION

Preserving Input Precision

Preserving input accuracy of the LTC6081/LTC6082 requires that the application circuit and PC board layout do not introduce errors comparable or greater than the $5\mu\text{V}$ typical offset of the amplifiers. Temperature differentials across the input connections can generate thermocouple voltages of 10's of microvolts so the connections to the input leads should be short, close together and away from heat dissipating components. Air current across the board can also generate temperature differentials.

The extremely low input bias currents (0.1pA typical) allow high accuracy to be maintained with high impedance sources and feedback resistors. Leakage currents on the PC board can be higher than the input bias current. For example, $10\text{G}\Omega$ of leakage between a 5V supply lead and an input lead will generate 500pA ! Surround the input leads with a guard ring driven to the same potential as the input common mode voltage to avoid excessive leakage in high impedance applications.

Capacitive Load

LTC6081/LTC6082 can drive capacitive load up to 200pF in unity gain. The capacitive load driving capability increases as the amplifier is used in higher gain configurations. A small series resistance between the output and the load further increases the amount of capacitance the amplifier can drive.

SHDN Pins

Pins 5 and 6 are used for power shutdown on the LTC6081 in the DD package. If they are floating, internal current sources pull Pins 5 and 6 to V^+ and the amplifiers operate normally. In shutdown, the amplifier output is high impedance, and each amplifier draws less than $2\mu\text{A}$ current.

Rail-to-Rail Input

The input stage of LTC6081/LTC6082 combines both PMOS and NMOS differential pairs, extending its input common mode voltage range to both positive and negative supply voltages. At high input common mode range, the NMOS pair is on. At low common mode range, the PMOS pair is on. The transition happens when the common voltage is between 1.3V and 0.9V below the positive supply. LTC6081 has better low frequency noise performance with PMOS input on due to its lower flicker noise (see Voltage Noise vs Frequency and 0.1Hz to 10Hz Input Voltage Noise in Typical Performance Characteristics).

Thermal Hysteresis

Figure 1 shows the input offset voltage hysteresis of the LTC6081IMS8 for 3 thermal cycles from -45°C to 90°C . The typical offset shift is $\pm 4\mu\text{V}$. The data was taken with the ICs in stress free sockets. Mounting to PC boards may cause additional hysteresis due to mechanical stress. The LTC6081 will meet offset voltage specifications in the electrical characteristics table even after $15\mu\text{V}$ of additional error from thermal hysteresis.

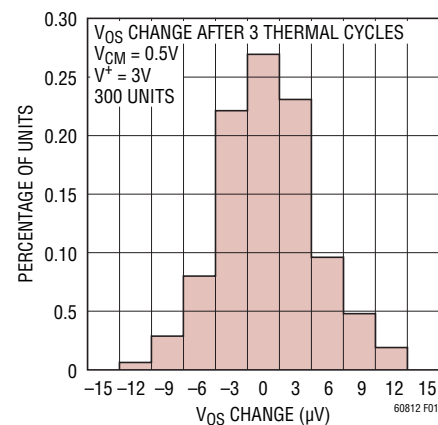

Figure 1. V_{OS} Thermal Hysteresis of LTC6081MS8

APPLICATIONS INFORMATION

PC Board Layout

Mechanical stress on a PC board and soldering-induced stress can cause the V_{OS} and V_{OS} drift to shift. The DD and DHC packages are more sensitive to stress. A simple way to reduce the stress-related shifts is to mount the IC near the short edge of the PC board, or in a corner. The board edge acts as a stress boundary, or a region where the flexure of the board is minimum. The package should always be mounted so that the leads absorb the stress

and not the package. The package is generally aligned with the leads perpendicular to the long side of the PC board (see Figure 2).

The most effective technique to relieve the PC board stress is to cut slots in the board around the op amp. These slots can be cut on three sides of the IC and the leads can exit on the fourth side. Figure 2 shows the layout of a LTC6081DD with slots at three sides.

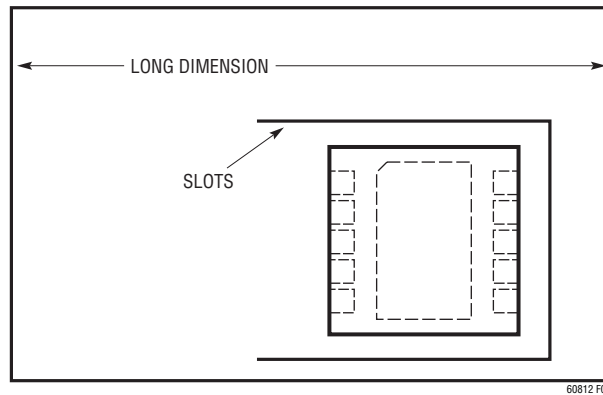
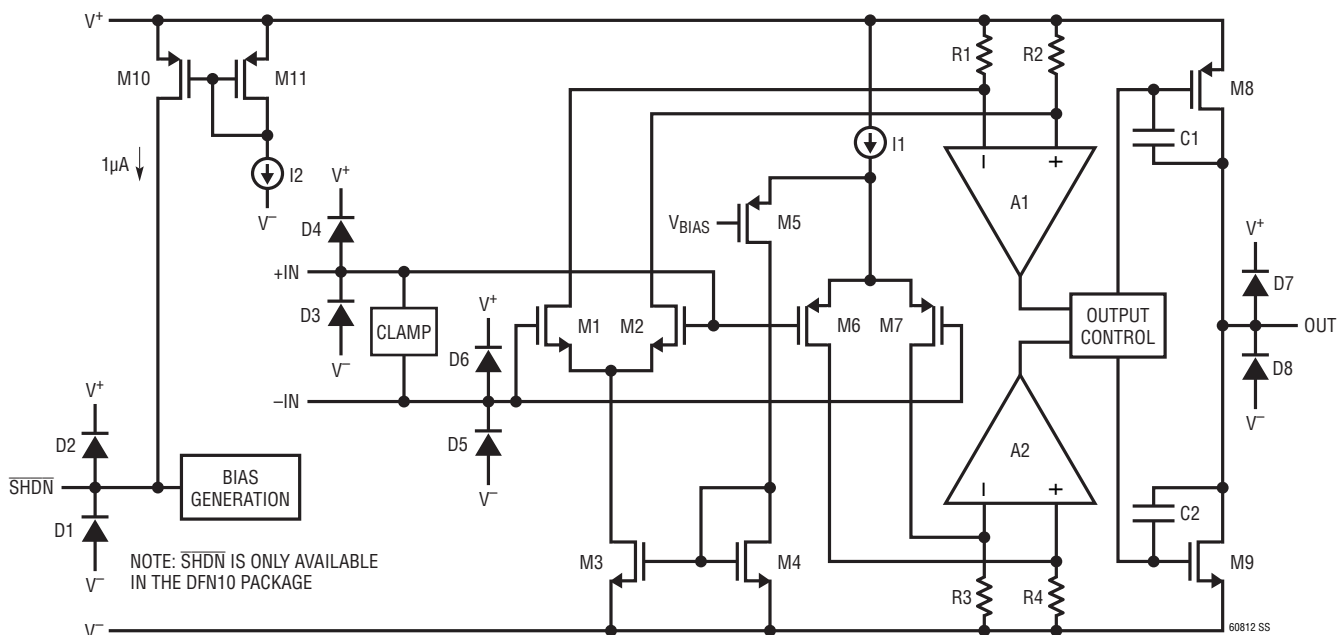

Figure 2. Vertical Orientation of LTC6081DD with Slots

SIMPLIFIED SCHEMATIC

Simplified Schematic of the Amplifier



60812fd

TYPICAL APPLICATIONS

Low Side Current Sense

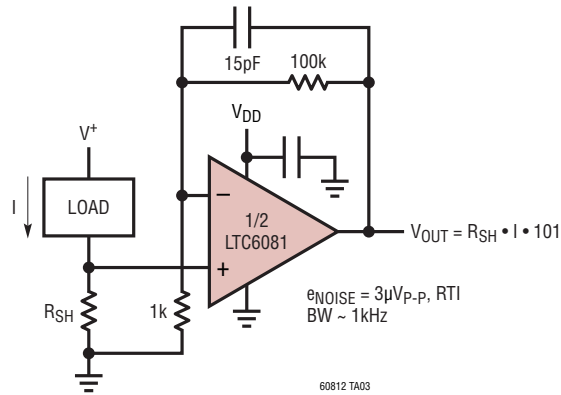

Two Op-Amp Instrumentation Amplifier

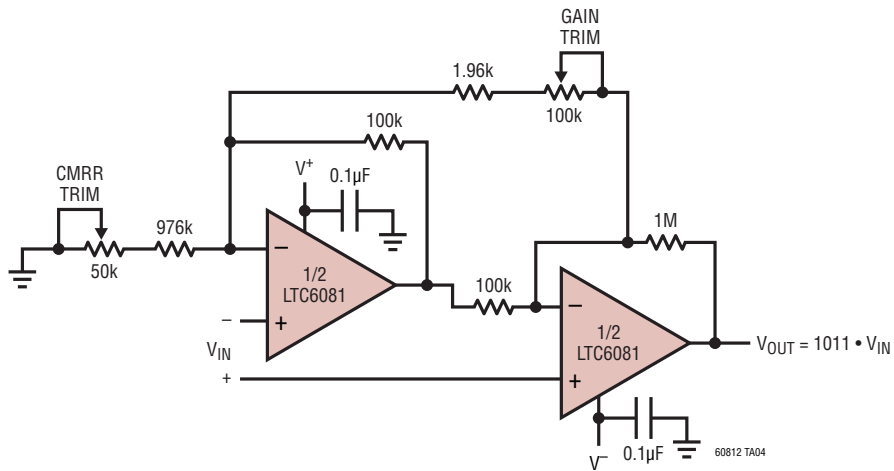

TYPICAL APPLICATIONS

Thermocouple Amplifier

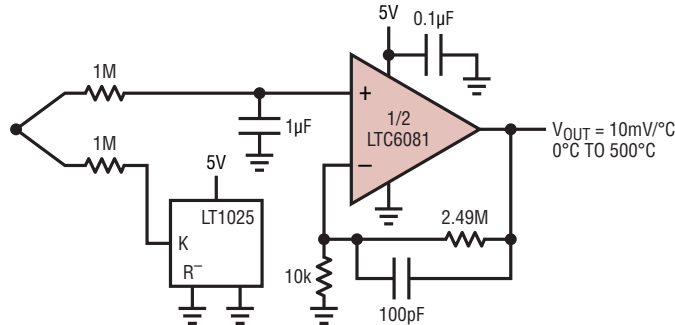

SENSOR: OMEGA 5TC-TT-K-30-36 K-TYPE THERMOCOUPLE
 1M RESISTORS PROTECT CIRCUIT TO $\pm 350V$ WITH NO PHASE REVERSAL OF AMPLIFIER OUTPUT
 1pA MAX I_{BIAS} TRANSLATES TO 0.05°C ERROR
 20µV V_{OS} \rightarrow 0.5°C OFFSET

60812 TA05

Precision Nanoamp Bidirectional Current Source

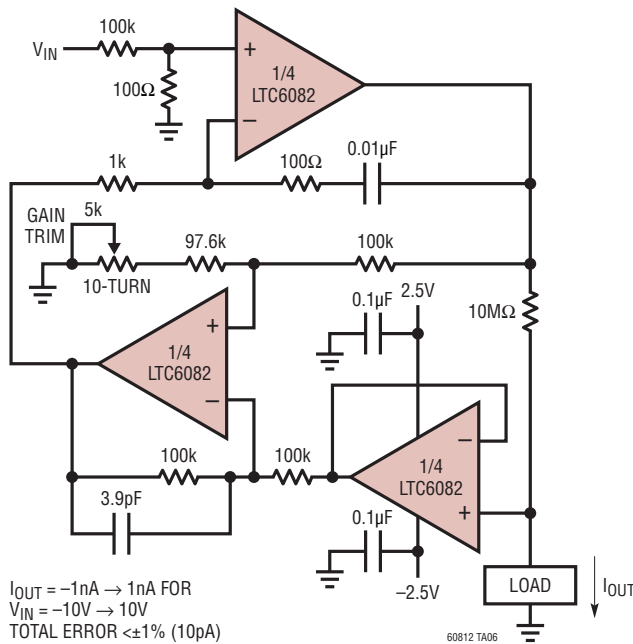

$I_{OUT} = -1nA \rightarrow 1nA$ FOR
 $V_{IN} = -10V \rightarrow 10V$
 TOTAL ERROR $< \pm 1\%$ (10pA)

60812 TA06

PACKAGE DESCRIPTION

Please refer to <http://www.linear.com/designtools/packaging/> for the most recent package drawings.

DD Package
10-Lead Plastic DFN (3mm × 3mm)
 (Reference LTC DWG # 05-08-1699 Rev C)

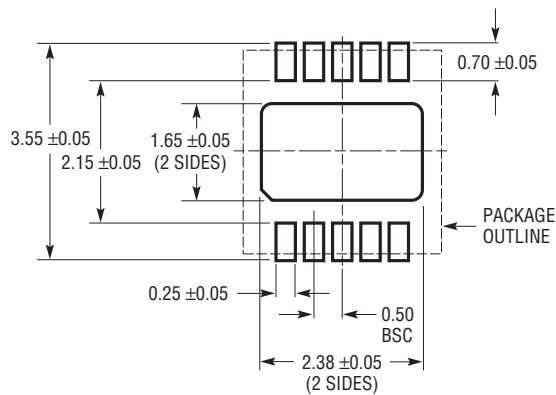

RECOMMENDED SOLDER PAD PITCH AND DIMENSIONS

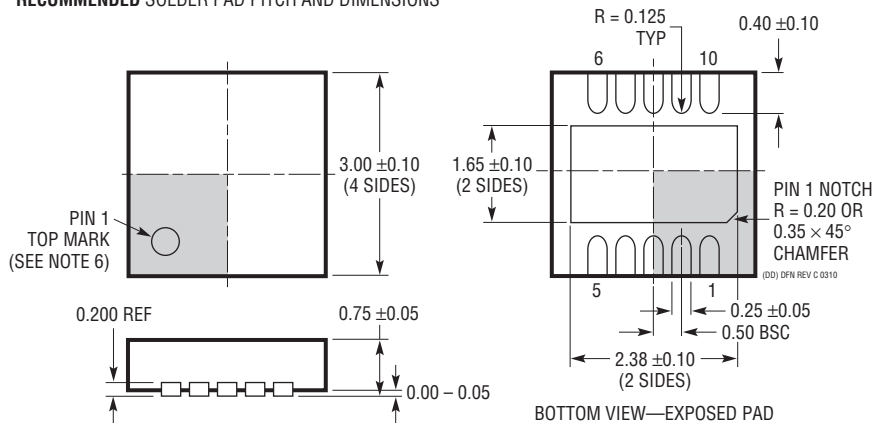

NOTE:

1. DRAWING TO BE MADE A JEDEC PACKAGE OUTLINE M0-229 VARIATION OF (WEED-2). CHECK THE LTC WEBSITE DATA SHEET FOR CURRENT STATUS OF VARIATION ASSIGNMENT
2. DRAWING NOT TO SCALE
3. ALL DIMENSIONS ARE IN MILLIMETERS
4. DIMENSIONS OF EXPOSED PAD ON BOTTOM OF PACKAGE DO NOT INCLUDE MOLD FLASH. MOLD FLASH, IF PRESENT, SHALL NOT EXCEED 0.15mm ON ANY SIDE
5. EXPOSED PAD SHALL BE SOLDER PLATED
6. SHADED AREA IS ONLY A REFERENCE FOR PIN 1 LOCATION ON THE TOP AND BOTTOM OF PACKAGE

PACKAGE DESCRIPTION

Please refer to <http://www.linear.com/designtools/packaging/> for the most recent package drawings.

DHC Package
16-Lead Plastic DFN (5mm × 3mm)
 (Reference LTC DWG # 05-08-1706 Rev 0)

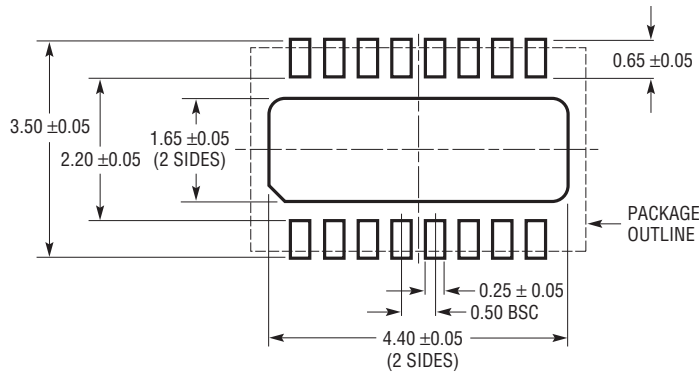

RECOMMENDED SOLDER PAD PITCH AND DIMENSIONS

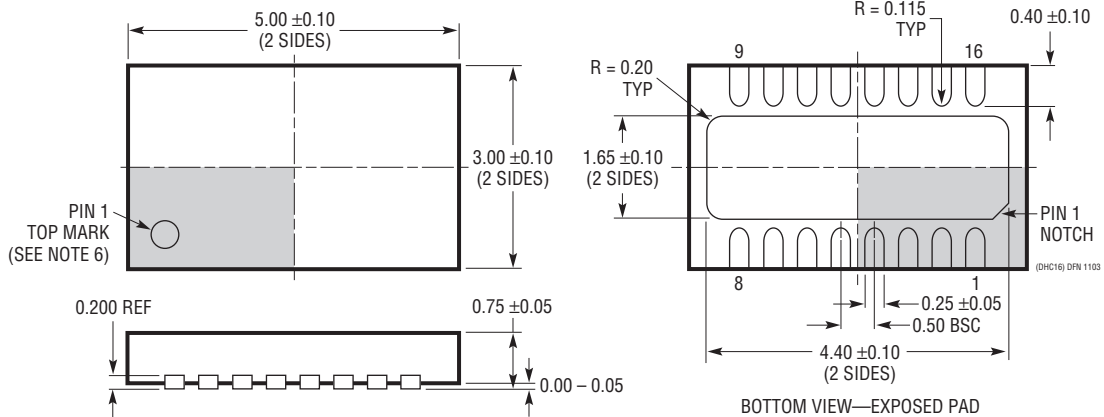

- NOTE:
1. DRAWING PROPOSED TO BE MADE VARIATION OF VERSION (WJED-1) IN JEDEC PACKAGE OUTLINE MO-229
 2. DRAWING NOT TO SCALE
 3. ALL DIMENSIONS ARE IN MILLIMETERS
 4. DIMENSIONS OF EXPOSED PAD ON BOTTOM OF PACKAGE DO NOT INCLUDE MOLD FLASH. MOLD FLASH, IF PRESENT, SHALL NOT EXCEED 0.15mm ON ANY SIDE
 5. EXPOSED PAD SHALL BE SOLDER PLATED
 6. SHADED AREA IS ONLY A REFERENCE FOR PIN 1 LOCATION ON THE TOP AND BOTTOM OF PACKAGE

PACKAGE DESCRIPTION

Please refer to <http://www.linear.com/designtools/packaging/> for the most recent package drawings.

GN Package 16-Lead Plastic SSOP (Narrow .150 Inch)

(Reference LTC DWG # 05-08-1641 Rev B)

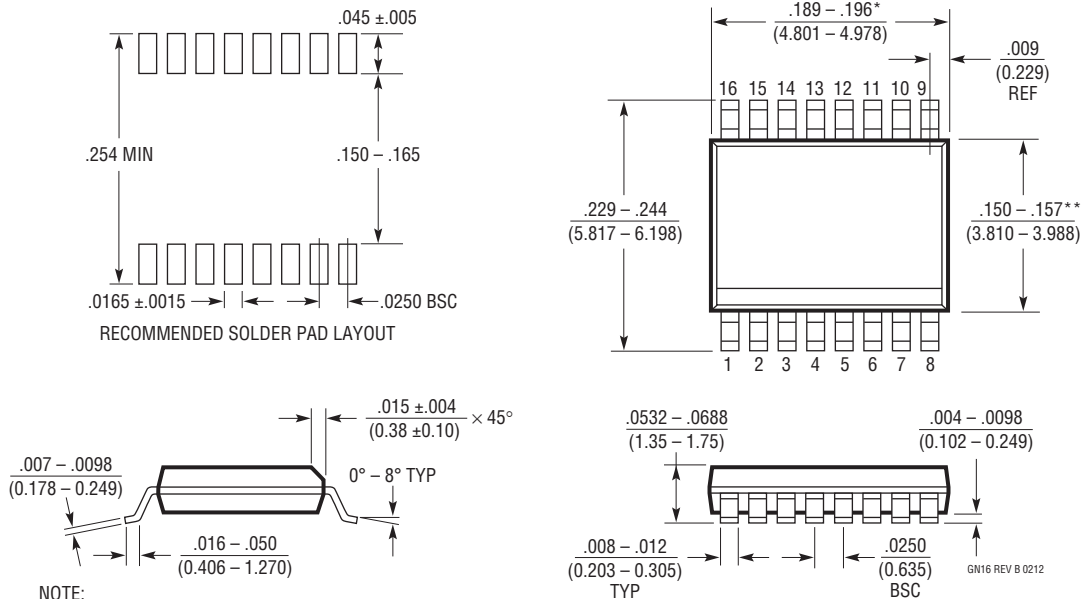

PACKAGE DESCRIPTION

Please refer to <http://www.linear.com/designtools/packaging/> for the most recent package drawings.

MS8 Package 8-Lead Plastic MSOP

(Reference LTC DWG # 05-08-1660 Rev G)

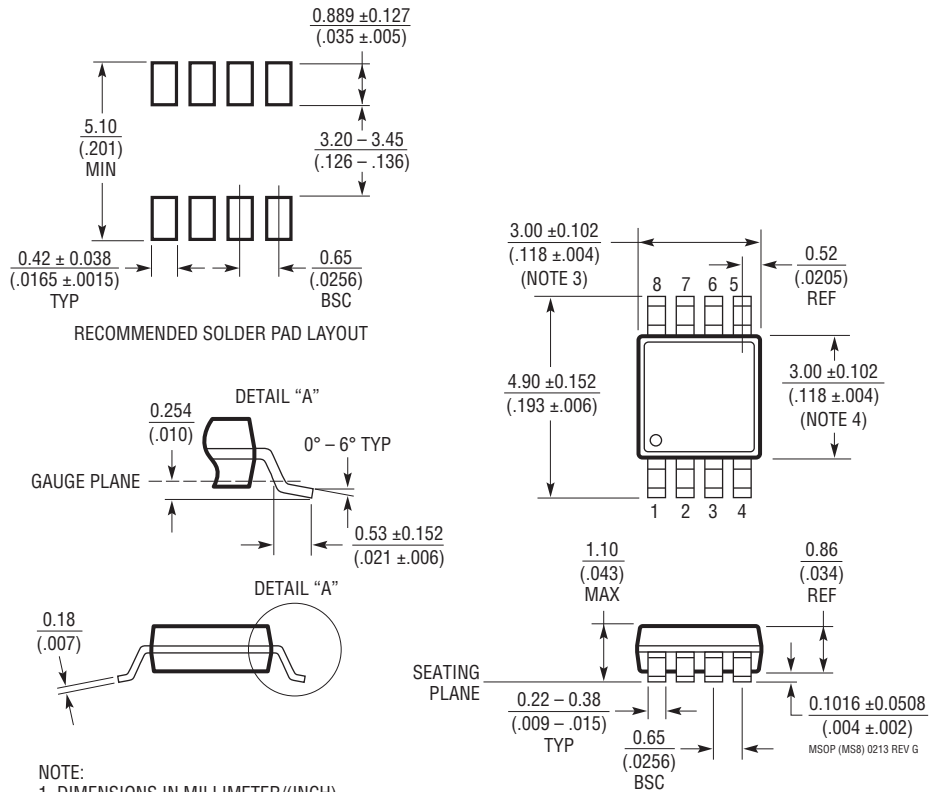

NOTE:

1. DIMENSIONS IN MILLIMETER/(INCH)
2. DRAWING NOT TO SCALE
3. DIMENSION DOES NOT INCLUDE MOLD FLASH, PROTRUSIONS OR GATE BURRS.
MOLD FLASH, PROTRUSIONS OR GATE BURRS SHALL NOT EXCEED 0.152mm (.006") PER SIDE
4. DIMENSION DOES NOT INCLUDE INTERLEAD FLASH OR PROTRUSIONS.
INTERLEAD FLASH OR PROTRUSIONS SHALL NOT EXCEED 0.152mm (.006") PER SIDE
5. LEAD COPLANARITY (BOTTOM OF LEADS AFTER FORMING) SHALL BE 0.102mm (.004") MAX

REVISION HISTORY (Revision history begins at Rev B)

REV	DATE	DESCRIPTION	PAGE NUMBER
B	3/10	Change LT to LTC on all part numbers in Order Information Section.	3
C	07/10	Update to Simplified Schematic	12
D	12/13	Corrected resistor value (10M)	14

TYPICAL APPLICATION

Single Supply Strain Gauge Amplifier

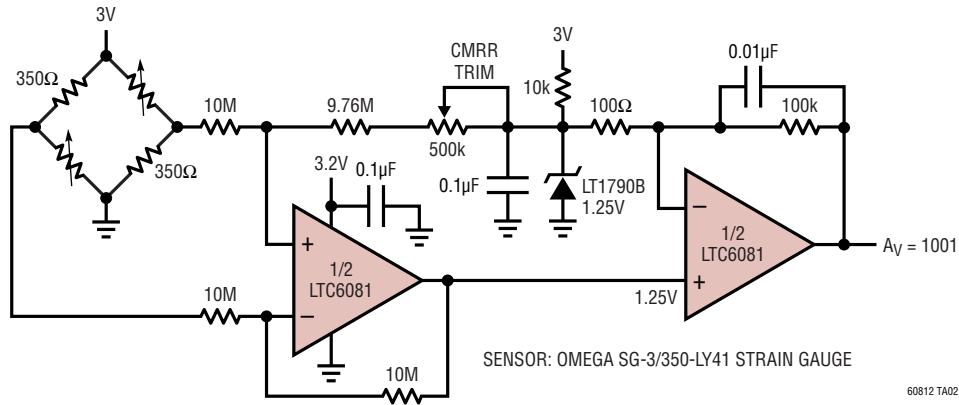

RELATED PARTS

PART NUMBER	DESCRIPTION	COMMENTS
LT1678/LT1679	Dual/Quad Precision Op Amps	Low Noise, 2.7V to 36V Operation
LTC2050	Zero-Drift Op Amp	2.7V Operation, SOT-23 Package
LTC2051/LTC2052	Dual/Quad Zero-Drift Op Amps	MS8/GN16 Packages
LTC2054/LTC2055	Single/Dual Zero-Drift Op Amp	Micropower, SOT-23 and DFN Packages
LTC6078/LTC6079	Dual/Quad Low Noise Precision CMOS Op Amps	Micropower 0.7µV/°C V _{OS} Drift
LTC6241/LTC6242	Dual/Quad Low Noise CMOS Op Amps	18MHz Bandwidth, 10V/µs Slew Rate
LTC6244	Dual 50MHz CMOS Op Amp	Low Noise, Rail-to-Rail Out, MS8 and DFN Packages